



S-MOWER-M

DURCH QUALITÄT ZUR WELTMARKE
UN MARCHIO INTERNAZIONALE GRAZIE ALLA SUA QUALITÀ
A GLOBAL BRAND THANKS TO ITS QUALITY

VARIANTEN

VERSIONI VARIANT

S-MOWER M-H

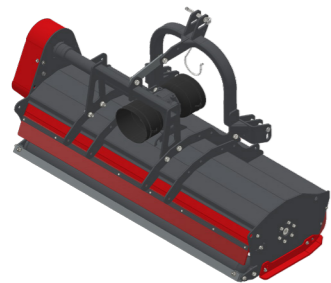

Fixer Heckanbau
Attacco fisso posteriore
Fix rear mounting

S-MOWER M-F



Fixer Frontanbau
Attacco fisso frontale
Fix front mounting

S-MOWER M-FH

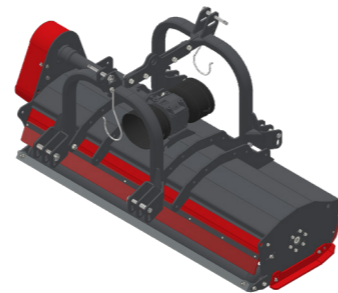

Fixer Front/Heckanbau
Attacco frontale-posteriore
Front- rear mounting

S-MOWER M-HL

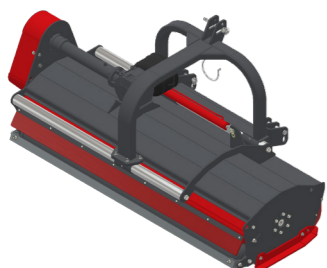

Heckanbau mit hydraulischer
Linearverschiebung
Spostamento idraulico posteriore
Hydraulic side shift rear

S-MOWER M-FL

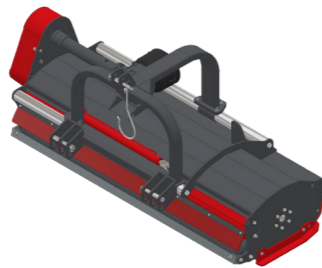

Frontanbau mit hydraulischer
Linearverschiebung
Spostamento idraulico frontale
Front hydraulic side shift

S-MOWER M-FHL

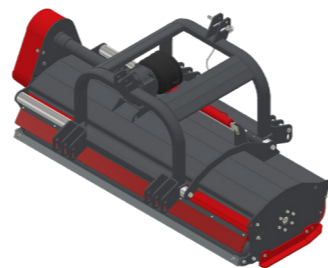

Front- Heckanbau mit hydraulischer
Linearverschiebung
Spostamento idraulico
Hydraulic side shift

S-MOWER M S-MOWER M

SERIENAUSSTATTUNG ACCESSORI DI SERIE STANDARD EQUIPMENT ZUSATZAUSRÜSTUNG ACCESSORI ADDITIONAL EQUIPMENT

DE Ausstattung auf Traktor notwendig:

- 1 DW Steuergerät für hyd. Ausladung

Serienausstattung auf dem Mulchgerät:

- Zapfwelle 540/min oder 1000/min
- Freilauf im Getriebe
- Hydraulischer Seitenvershub
- Automatischer Riemenspanner
- Doppeltes Gehäuse
- Einstellbare Stützwalze mit Grasabstreifer
- Kettenschürzen vorne
- Verstellbare Heckklappe mit Gummischutz
- Dreipunkt CAT 1+2
- Gegenschniden
- CE Unfallschutz

IT Accessori necessari sulla trattrice:

- 1 Distributore doppio effetto per spostamento idraulico lineare

Accessori di serie sulla trinciaerba:

- PTO 540/min o 1000/min
- Riduttore con ruota libera
- Spostamento laterale idraulico lineare
- Tendicinghia automatico
- Carcassa doppia
- Rullo regolabile con raschiarullo
- Protezioni a catena anteriore
- Cofano regolabile con protezione in gomma
- Attacco trepunti CAT 1+2
- Controlame
- Protezioni antinfortunistiche a norme CE

EN For standard equipment on tractor needed

- 1 double acting control unit for hydraulic side shift

Standard equipment on S-Mower

- PTO 540/min or 1000/min
- Freewheel in the gearbox
- Hydraulic side shift
- Automatic belt tensioner
- Double frame
- Adjustable roller support with roller scraper
- Chain guard front
- Adjustable hood with protective rubber in the rear
- Three point CAT 1+2
- Shearbars
- CE-accident protection

SCHLÄGELMULCHER FÜR GRAS UND REISSIG Ø 5-6 CM

TRINCIAERBA PER ERBA E POTATURA Ø 5-6 CM

FLAIL MOWER FOR GRAS AND PRUNINGS Ø 5-6 CM

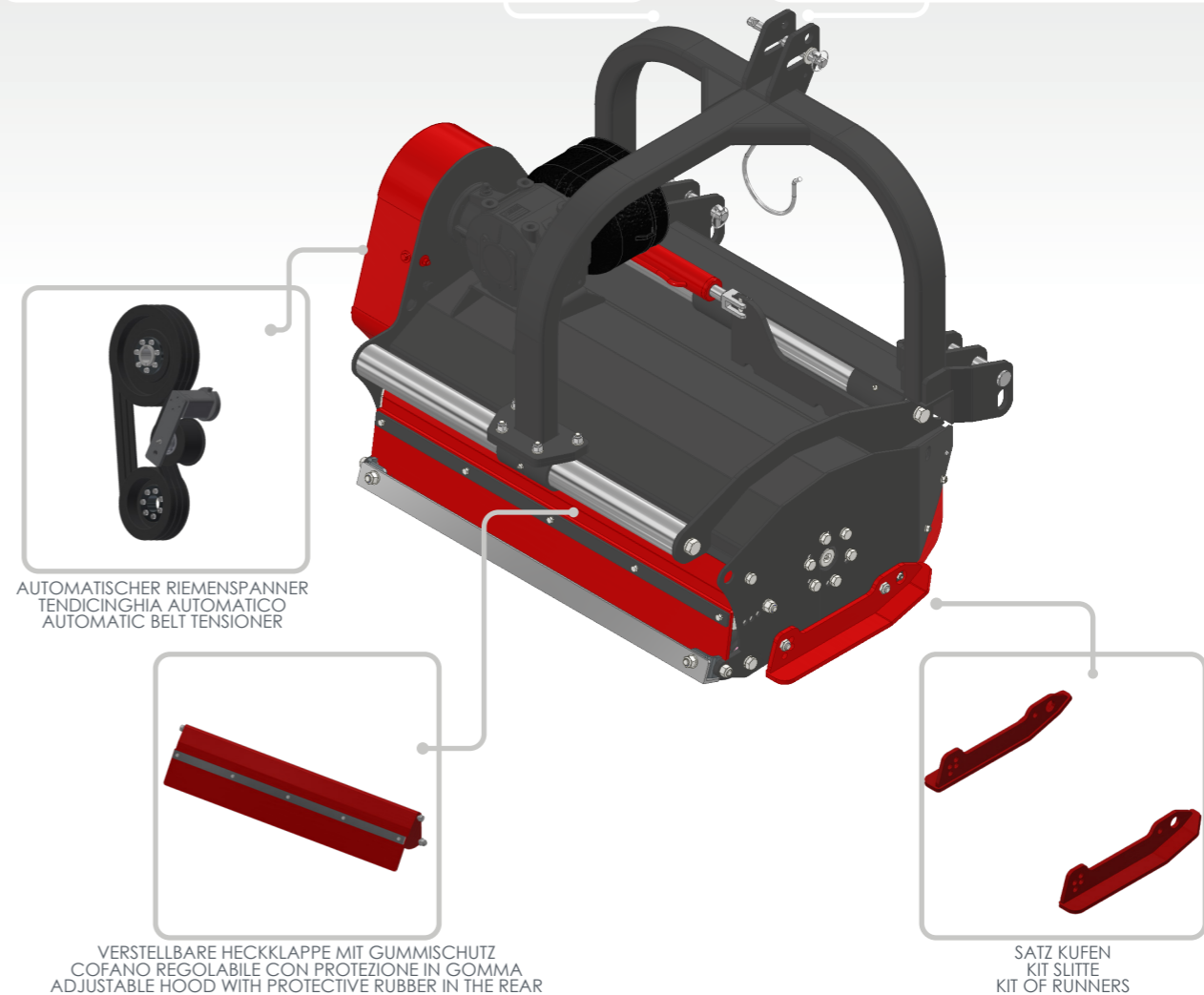
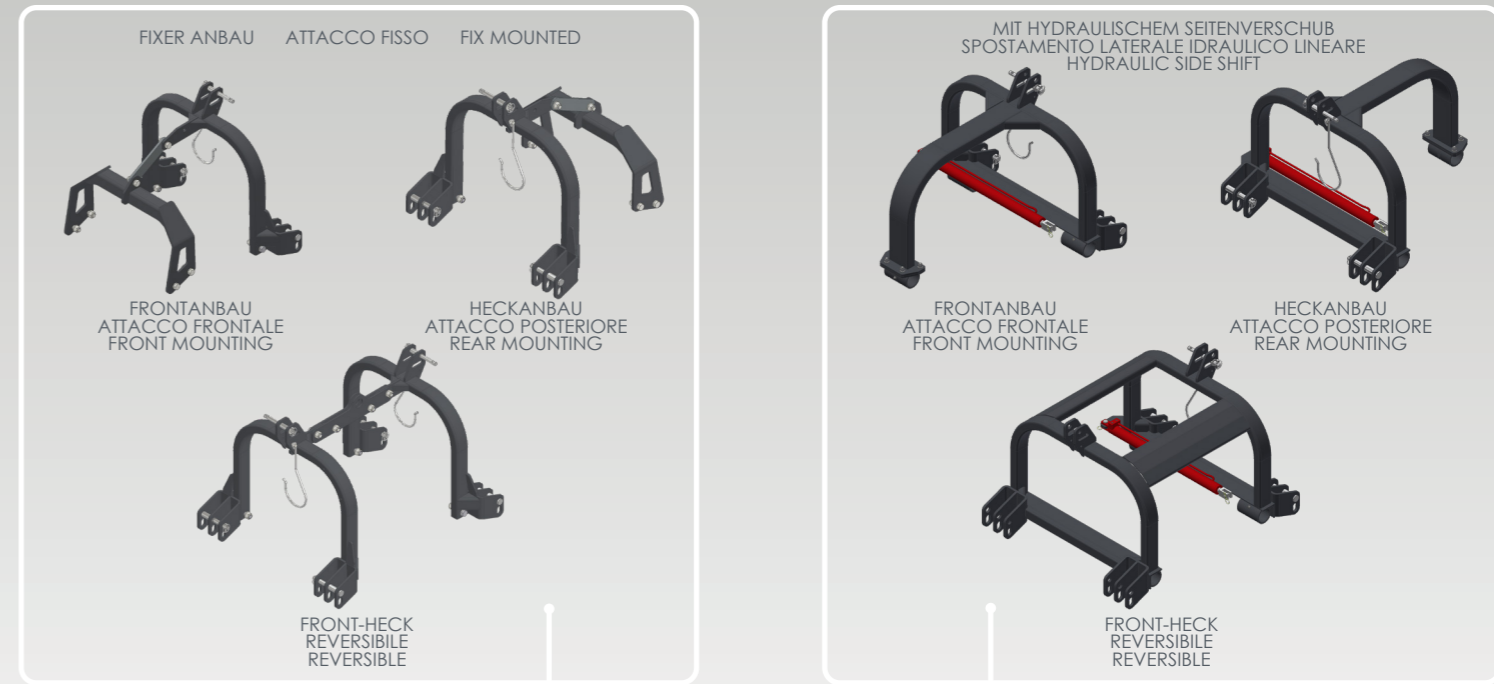

Mod.	SCHLÄGEL MAZZE HAMMER	HP	HYD FIX		Arbeitsbreite Larghezza di lavoro Working width	3	A B C D E					cm / ø Fixer Anbau Attacco fisso Fix mounted		cm / ø Hyd. Seitenvershub Spostamento idr. Hyd. sideshift	
			440	390			120	43	71	104	93	140	40/80	64/57	
S-MOWER-M 125	10	30-90	440	390	120	3	43	71	104	93	140	40/80	64/57		
S-MOWER-M 150	12	30-90	480	445	145	3	43	71	104	93	165	60/60	14/107		
S-MOWER-M 175	14	30-90	530	470	170	4	43	71	104	93	191	53/93	73/72		
S-MOWER-M 200	16	30-90	570	510	195	4	43	71	104	93	216	73/73	14/131		
												65/105	84/84		
												85/85	27/143		
												78/118	99/97		
												98/98	40/156		

Alle Angaben beziehen sich auf das Grundgerät Tutti i dati tecnici si riferiscono alla macchina „base“ senza accessori All information relates to the basic device