

**S-MOWER-L**

DURCH QUALITÄT ZUR WELTMARKE  
UN MARCHIO INTERNAZIONALE GRAZIE ALLA SUA QUALITÀ  
A GLOBAL BRAND THANKS TO ITS QUALITY

**VARIANTEN**

VERSIONI VARIANT

S-MOWER L-H

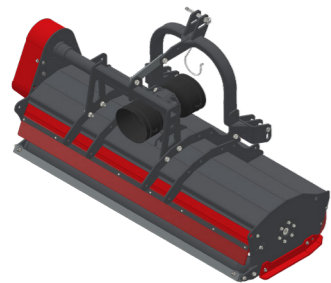

Fixer Heckanbau  
Attacco fisso posteriore  
Fix rear mounting

S-MOWER L-F

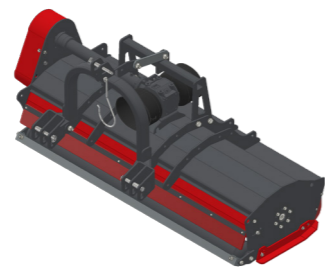

Fixer Frontanbau  
Attacco fisso frontale  
Fix front mounting

S-MOWER L-FH

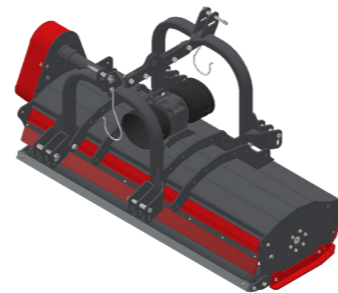

Fixer Front/Heckanbau  
Attacco frontale-posteriore  
Front- rear mounting

S-MOWER L-HL

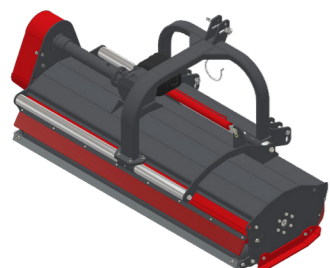

Heckanbau mit hydraulischer  
Linearverschiebung  
Spostamento idraulico posteriore  
Hydraulic side shift rear

S-MOWER L-FL

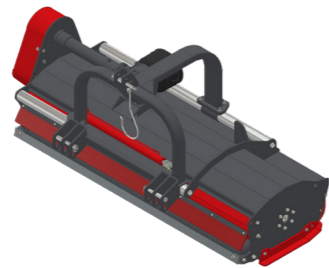

Frontanbau mit hydraulischer  
Linearverschiebung  
Spostamento idraulico frontale  
Front hydraulic side shift

S-MOWER L-FHL

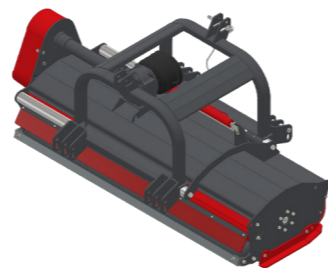

Front- Heckanbau mit hydraulischer  
Linearverschiebung  
Spostamento idraulico  
Hydraulic side shift

# S-MOWER L S-MOWER L

SERIENAUSSTATTUNG

ACCESSORI DI SERIE

STANDARD EQUIPMENT

ZUSATZAUSRÜSTUNG

ACCESSORI

ADDITIONAL EQUIPMENT

## DE Ausstattung auf Traktor notwendig:

- 1 DW Steuergerät für hyd. Ausladung

### Serienausstattung auf dem Mulchgerät:

- Zapfwelle 540/min oder 1000/min
- Freilauf im Getriebe
- Hydraulischer Seitenvershub
- Automatischer Riemenspanner
- Doppeltes Gehäuse
- Einstellbare Stützwalze mit Grasabstreifer
- Kettenschürzen vorne
- Verstellbare Heckklappe mit Gummischutz
- Dreipunkt CAT 1+2
- Gegenschniden
- CE Unfallschutz

## IT Accessori necessari sulla trattrice:

- 1 Distributore doppio effetto per spostamento idraulico lineare

### Accessori di serie sulla trinciaerba:

- PTO 540/min o 1000/min
- Riduttore con ruota libera
- Spostamento laterale idraulico lineare
- Tendicinghia automatico
- Carcassa doppia
- Rullo regolabile con raschiarullo
- Protezioni a catena anteriore
- Cofano regolabile con protezione in gomma
- Attacco trepunti CAT 1+2
- Controlame
- Protezioni antinfortunistiche a norme CE

## EN For standard equipment on tractor needed

- 1 double acting control unit for hydraulic side shift

### Standard equipment on S-Mower

- PTO 540/min or 1000/min
- Freewheel in the gearbox
- Hydraulic side shift
- Automatic belt tensioner
- Double frame
- Adjustable roller support with roller scraper
- Chain guard front
- Adjustable hood with protective rubber in the rear
- Three point CAT 1+2
- Shearbars
- CE-accident protection

SCHLÄGELMULCHER FÜR GRAS UND REISSIG Ø 3-4 CM

TRINCIAERBA PER ERBA E POTATURA Ø 3-4 CM

FLAIL MOWER FOR GRAS AND PRUNINGS Ø 3-4 CM

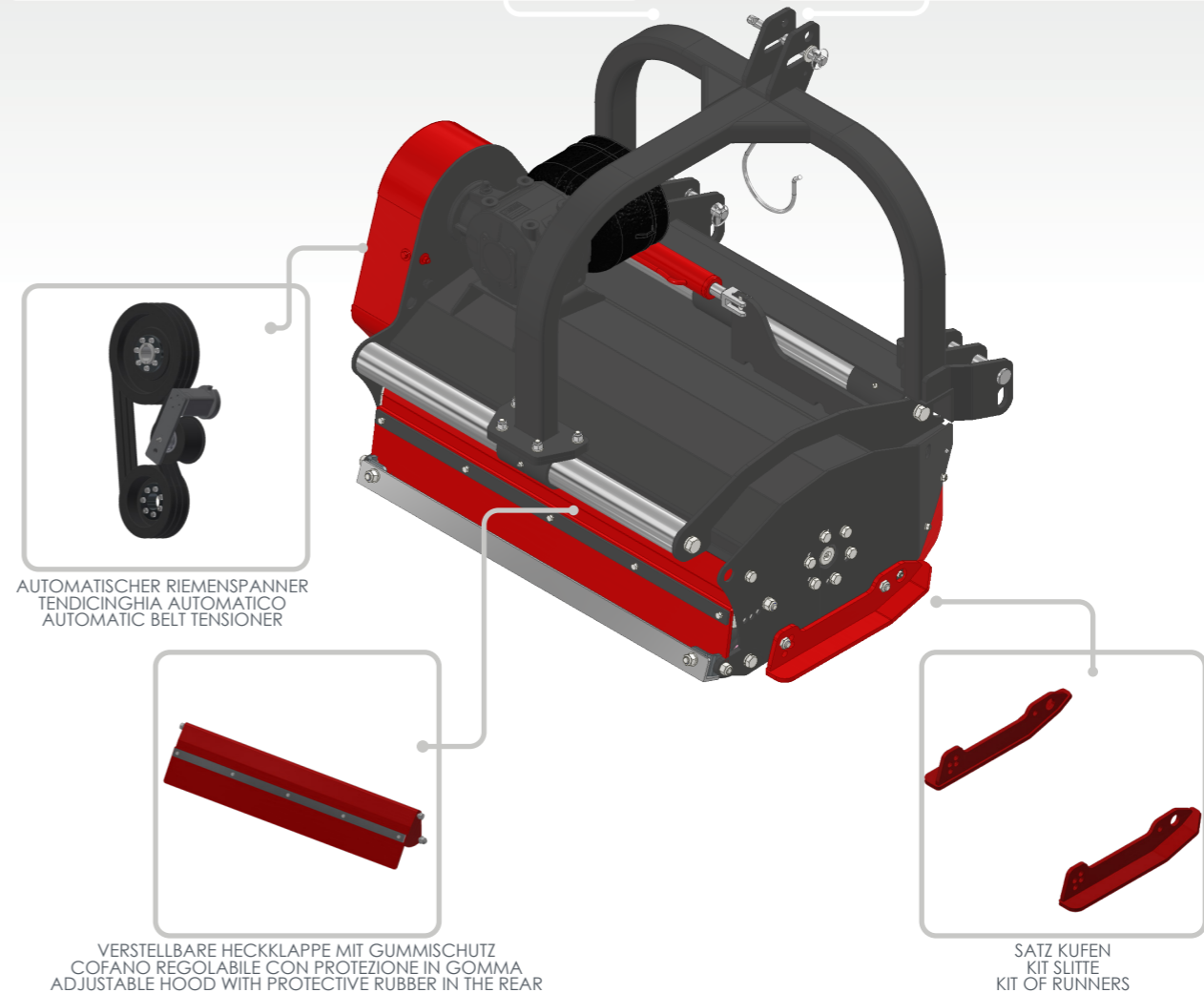
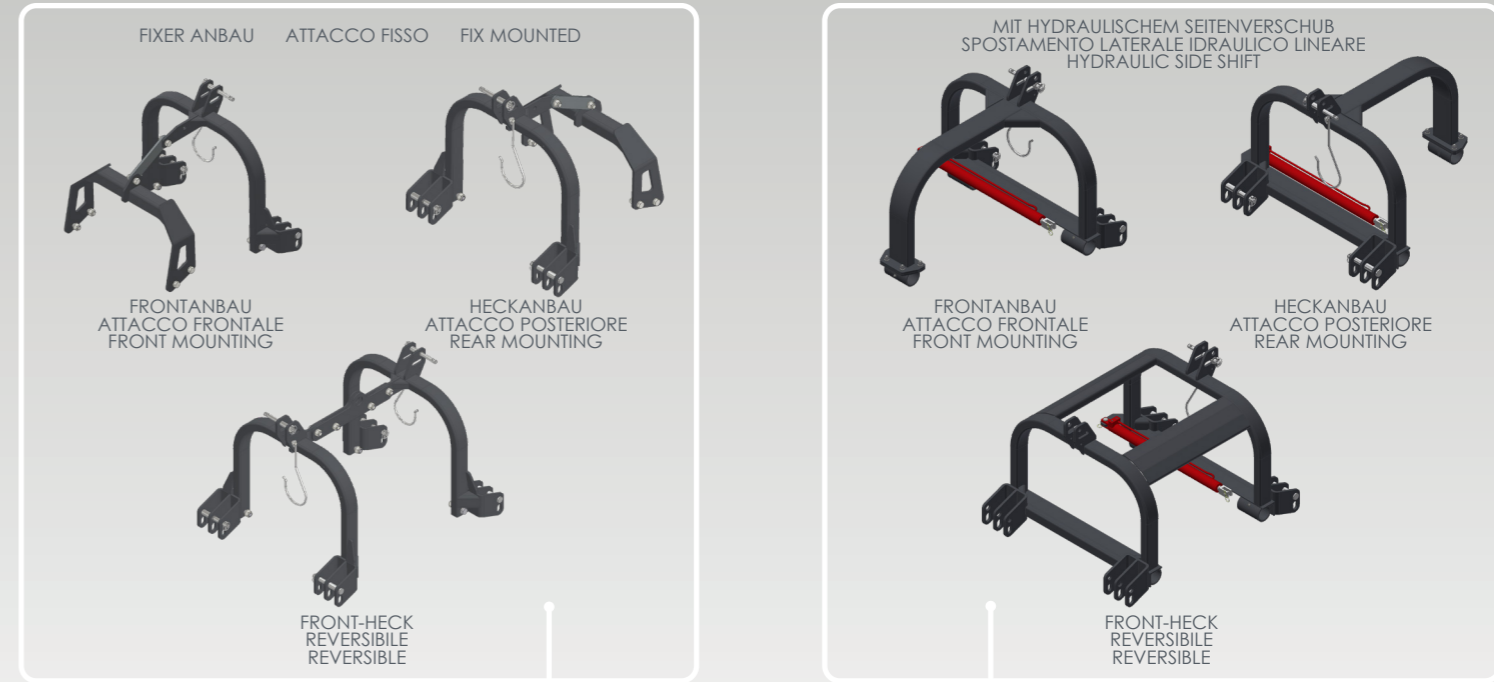

Mod.	SCHLÄGEL MAZZE HAMMER	HP	HYD FIX		Arbeitsbreite Larghezza di lavoro Working width	3	A B C D E					cm / ø Fixer Anbau Attacco fisso Fix mounted	cm / ø Hyd. Seiten- vershub Spostamento idr. Hyd. sideshift
			345	350			95	41	68	103	90		
S-MOWER-L 100	8	20-50	345	350	95	3	41	68	103	90	114	47/48	45/50
S-MOWER-L 125	10	20-50	390	390	120	3	41	68	103	90	139	40/60 40/80	64/56 14/106
S-MOWER-L 150	12	20-50	430	430	145	3	41	68	103	90	164	72/73 52/93	73/72 14/131
S-MOWER-L 175	14	20-50	470	470	170	3	41	68	103	90	189	85/85 65/105	84/84 27/143

Alle Angaben beziehen sich auf das Grundgerät

Tutti i dati tecnici si riferiscono alla macchina „base“ senza accessori

All information relates to the basic device